

LIMITING THERMAL LOADS IN WATER BOILING IN VERTICAL CHANNELS  
UNDER NATURAL CIRCULATION CONDITIONS

A. I. Leont'ev, O. O. Mil'man, and V. A. Fedorov

UDC 536.423:621.187.16

An experimental study is performed and results generalized for limiting thermal loads in water boiling for the pressure range 5-90 kPa in vertical tubes heated by condensing water vapor, as used in low-pressure head natural circulation systems.

Interest has recently developed in high-efficiency evaporator or distiller-type heat-exchange systems with natural circulation of the boiling heat-transfer agent. In developing compact equipment of this type, a unique form of crisis phenomenon is met, in which the quantity of heat removed is limited to some maximum value, which we will refer to in the future as the limiting thermal load  $Q_*$ . Such a situation appears to be typical for an entire class of heat-exchange apparatus heated by condensing vapor or hot water. The onset of the heat-exchange crisis in such devices does not lead to dangerous overheating of the heat-transfer surface and imposes no limitations on the operation of the equipment: the total thermal load can still increase after zones of degraded heat transfer or areas not wetted by liquid are formed on the vapor generating surface. However, the existence of limiting thermal loads is an important limiting factor in utilization of these heat-exchange devices. It should be noted that determination of the value of the limiting load is an independent problem and, in the general case, does not reduce to determination of the heat-exchange crisis in boiling.

Analysis of the available data permits the conclusion that the quantity of heat removed by the heat-transfer agent would be maximal if the entire surface of the vapor generating channel were covered by a microfilm of liquid. For this case three conditions would be fulfilled: the heat-liberation coefficient would be maximal [1]; the hydraulic resistance would be at a minimum [2]; and the moving natural circulation pressure head would be close to its maximum. However, in reality, simultaneous satisfaction of these three conditions is impossible. This is due to the existence of instability in liquid boiling in vertical tubes, and the presence of various flow regimes along the height of the vapor generating channel. Solution of this problem is complicated by the absence of data on the heat-exchange crisis in the saturation temperature range 30-100°C.

In [3] an attempt was made to determine the limiting thermal load as a function of geometric dimensions of the natural circulation contour and heat-exchange agent parameters.

The present study will examine results of an experimental investigation of limiting thermal loads  $Q_*$  for water boiling inside vertical tubes with a moving natural circulation head  $\Delta P_m$  not exceeding 15 kPa over the saturation temperature range 33-97°C.

The experimental apparatus (Fig. 1a) consisted of a closed natural circulation channel which includes the experimental heat exchanger 1 with vertical vapor generation tubes and evaporation condenser 2. Heat exchanger 1 is constructed of 101 stainless steel tubes with diameter  $6 \times 1$  mm, 1.52 m long. The tubes are bundled together in a staggered pattern forming equilateral triangles with 8-mm sides (Fig. 1b), 5 tubes wide by 21 tubes deep, producing an internal heat-exchange surface of 1.93 m<sup>2</sup>.

Before beginning the experiments, the system was evacuated and partially filled with de-aerated water having an oxygen content of no more than 10-15 µg/kg. The heating vapor was fed into the intertube space of heat exchanger 1, causing the water in the tubes to boil. The secondary vapor formed by the boiling was condensed in heat exchanger 2, with the condensate being fed into descent tube 4. Because of the difference in densities in the descent and

---

N. É. Bauman Higher Technical Institute, Moscow. Translated from *Inzhenerno-Fizicheskii Zhurnal*, Vol. 48, No. 4, pp. 621-628, April, 1985. Original article submitted July 14, 1983.

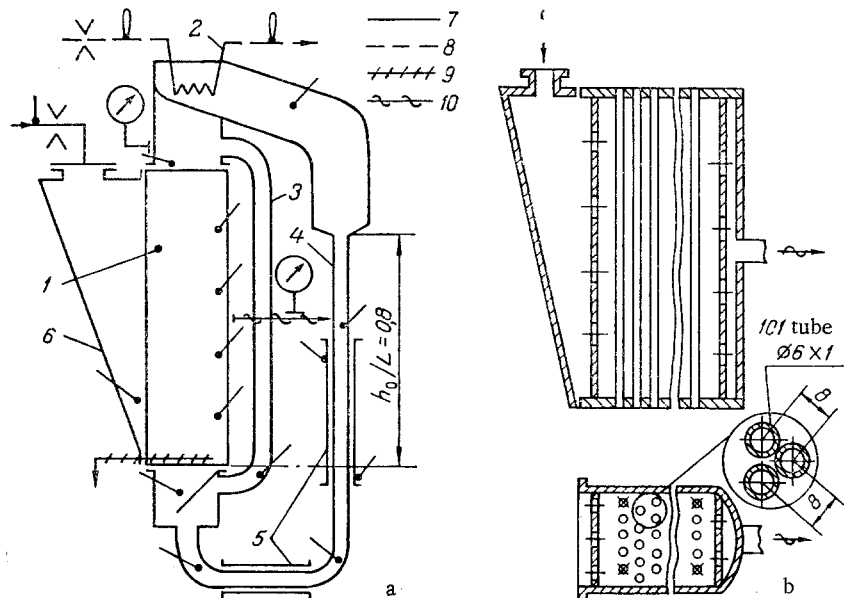

Fig. 1. Diagram of experimental apparatus (a) and working section (b): 1) heat exchanger with vertical tubes; 2) evaporation condenser; 3) overflow tube; 4) descent tube; 5) tube-within-tube heat exchanger; 6) vapor distributor connector; 7) heating vapor; 8) cooling water; 9) condensate; 10) vapor-air mixture.

vapor generation channels, a natural circulation of the heat-exchange agent develops. To avoid formation of a water layer above heat exchanger 1 a simple louvered separator was installed at its exit. Water from the separator was led off through overflow tube 3.

The water displaced from the vapor generation tubes during boiling is redistributed over the channel. The greater part enters the descent portion, the level in which increases in comparison to the initial state (with no thermal load). Some portion of the displaced water with mass  $m$  "spreads out" as a film on the surface of heat exchanger 2 and the channel walls.

The water levels in the descent and overflow tubes, and the amount expelled from the vapor generator tubes were monitored with water measuring columns. The descent section contained two "tube-within-a-tube" type heat exchangers 5 used to heat or cool the circulating fluid and measure the flow rate by the calorimetric method.

The total thermal load  $Q$  removed in the experimental heat exchanger 1 was determined by the heating and flow rate of cooling water in heat exchanger 2 and was periodically checked using the flow rate and parameters of the heating vapor or its condensate which was drained into a measurement vessel. The total limiting load for heat exchanger 1  $Q$  was 20-105 kW over the pressure range 5-90 kPa with initial filling levels  $h_0$  of 0.42-1.5 m in the vapor generator channels. The maximum discrepancy in thermal balance in the majority of cases was 2-3% of  $Q$ .

The moment at which the limiting load was attained was accompanied by the practically instantaneous appearance of a large quantity of water above the upper tube plate of the heat exchanger, where it remained suspended, since the mean velocity of the vapor at the exit of the vapor generation channels was much greater than the critical bubbling velocity [4]. At  $Q$  close to  $Q_*$  the experiments recorded only expulsion of individual droplets of liquid. After attainment of  $Q_*$  there was a decrease in the quantity of heat removed by the device, despite rapid growth in saturation temperature and pressure of the heating vapor.

The experimental results are depicted in Figs. 2 and 3 in the form of curves of the normalized limiting thermal load, referenced to the total transmission section of the vapor generator channels  $\bar{q}_* = Q_*/F_i$  as a function of regime and construction parameters. Such a presentation of the experimental data allows relative estimation of the limiting heat-transfer capability of evaporators with natural heating agent circulation for various supply methods to the vapor generating section [5].

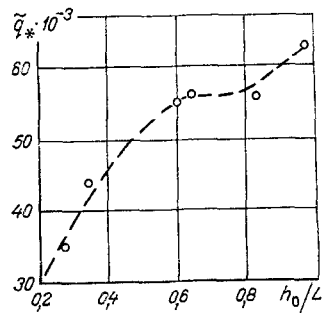

Fig. 2

Fig. 2. Quantity  $\tilde{q}_*$  ( $\text{kW/m}^2$ ) vs relative initial heat-exchange agent filling level in vapor generator tubes  $h_0/L$  at  $P_c = 17-21$  kPa.

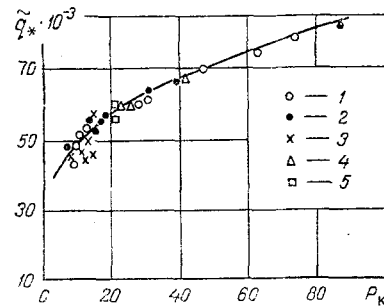

Fig. 3

Fig. 3. Quantity  $\tilde{q}_*$  ( $\text{kW/m}^2$ ) vs regime parameters at  $0.73 < \bar{h}_0/L < 0.83$ . Heating vapor: 1) superheated; 2) moist; 3) vapor generator tubes partially submerged at heating vapor end. Water at input to vapor generator tubes: 4) supercooled; 5) superheated.

It is evident from Fig. 2 that with increase in  $h_0/L$  the quantity  $\tilde{q}_*$  increases. The inflection point in the curve  $\tilde{q}_* = f(h_0/L)$  is related to an abrupt increase in the section of the descent section  $F_0$  at  $h_0/L = 0.8$  (see Fig. 1). A consequence of this increase in  $F_0$  is a decrease in the water level increment in the descent channel. In fact, the increase in this level occurs due to water displaced from the vapor generator channels. At  $h_0/L < 0.8$ , the ratio  $F_1/F_0 = 0.3$  and the level in the descent channel increases quite markedly, while at  $h_0/L > 0.8$  and a ratio  $F_1/F_0 = 0.045$  there is practically no level increase, since the section  $F_0$  is so large. Consequently, the increment in moving circulation head decreases for other conditions equal, and the character of the function  $\tilde{q}_* = f(h_0/L)$  changes, as is shown in Fig. 2.

Thus, analysis of the data of Fig. 2 permits the conclusion that the limiting thermal load depends on the initial filling level  $h_0$  and the ratio of the transmission sections of the vapor generator tubes and descent sections  $F_1/E_0$ .

Figure 3 shows the results of experiments performed at values  $0.73 < \bar{h}_0/L < 0.83$ , analyzing the effect of pressure above the vapor generator tubes  $P_c$ , water temperature at the output of the lower heat exchanger 5, state of the heating vapor, and length of the vapor or generator channel heated by vapor on limiting thermal load.

Sub- or superheating of the water was produced by "tube-within-a-tube" type heat exchangers in the descent section of the channel within the range  $t_s)_{-2}^{+3}$ , °C. Within this range no substantial effect of liquid temperature on limiting thermal load was detected.

In the experiments vapor superheating was varied from 0 to 30°C. This parameter also did not appear to affect  $\tilde{q}_*$ .

To determine the effect of the length of channel heated by vapor on the limiting thermal load the heating surface of heat exchanger 1 (see Fig. 1) was submerged up to 1 m in the condensate. The length of the tubes involved in intense heat exchange with the condensating vapor then decreased from 1.52 to 0.52 m. Estimation of the quantity of heat transferred from the heating vapor condensate to the water boiling within the tubes indicated that the former did not exceed 10% of the total load.

Analysis of the data presented in Fig. 3 permits the following conclusions:

the limiting thermal loads are determined primarily by the total quantity of heat supplied to the vapor generating tubes. They depend weakly on the length of the tube heated by the vapor;

the hydrodynamics of the boiling processes at thermal loads close to limiting are independent of sub- or superheating of the water supplied to the vapor generator tubes at  $P_c < 90$  kPa;

the limiting thermal loads increase with increase in pressure above the vapor generator tubes.

In the range of regime and geometric characteristics studied there is no relationship between  $Q_*$  and the heat exchange crisis of the first sort, where the limiting thermal load can be represented in the form

$$Q_* = q_{cf} \pi DL. \quad (1)$$

This is indicated, in particular, by the fact that change in the length of the section of the vapor generator tubes heated by vapor by a factor of more than two times produces practically no effect on the limiting thermal load (Fig. 3). In addition, the present data agree well with the results of [6]: the development of regimes with degraded heat liberation at  $q < q_{cr}$  depends on the total quantity of heat supplied to the vapor generator channel, and is defined by attainment of a limiting vapor content  $x_{lim}$ . However, in low-head natural circulation systems the heat-transfer agent velocity is not the dominant parameter, often being variable at  $Q = Q_*$ , so that generalization of the experimental data with use of  $x_{lim}$  is not possible.

A theoretical approach to analysis of  $Q_*$  is complicated by the fact that at thermal loads close to limiting thermohydrodynamic instability develops in the channel. It appears not only in the form of temperature and pressure oscillations, but also in oscillations of liquid column height with amplitude up to 0.3 m in the U-shaped vapor generator-descent tube system. The vapor generator channels then periodically fill with water or vapor formed by evaporation of the liquid film coating their surface. In such a boiling regime the major fraction of the heat is removed from the vapor generating surface coated by the liquid film, where heat exchange occurs quite intensely.

To clarify the interrelationship of  $Q_*$  and the heat-transfer agent parameters and geometrical characteristics of the natural circulation circuit we will turn to an examination of the quasi-steady-state problem, assuming that  $Q = Q_*$  the major portion of the vapor generator channel section is occupied by moving vapor, i.e.,  $\varphi \approx 1$ . In the region of low pressures and small circulation velocities such an assumption is close to reality. In this case attainment of the limiting thermal load will occur with drying of a portion of the liquid film coating the wall of the vapor generator channel.

Such an approach reduces determination of the limiting thermal loads to the steady-state problem of calculating the heat in accordance with the thermal balance equation

$$Q_* \approx \rho_c'' W_*'' r F_i. \quad (2)$$

The vapor velocity  $W_*''$  at the output of the vapor generator channels can be determined from the system of equations presented below, written for  $Q = Q_*$ .

The moving natural convection head

$$\Delta P_m^* \approx g [\bar{h}_0 \rho' + (L - \bar{h}_0) \rho_c'' - L \bar{\rho}''] = \Delta P_{fr}^* + \Delta P_{acc}^* \quad (3)$$

the losses to friction

$$\Delta P_{fr}^* \approx \int_0^L \xi \frac{\rho'' W''^2}{2} \frac{dx}{D}, \quad (4)$$

losses to acceleration

$$\Delta P_{acc}^* \approx \rho_c'' W_*''^2, \quad (5)$$

the vapor phase velocity in the vapor generator channel

$$W'' = \int_0^x \frac{4q}{r \rho'' D} dx = \frac{Q_* p(x)}{r \rho'' F_i}, \quad (6)$$

the liquid column height in the descent section

$$\bar{h}_0 = \frac{1}{\rho' - \rho_c''} \left[ (\rho' h_0 + (L - h_0) \rho_c'') \left( 1 + \frac{F_i}{F_0} \right) - L \left( \rho_c'' + \bar{\rho}'' \frac{F_i}{F_0} \right) - \frac{m}{F_0} \right], \quad (7)$$

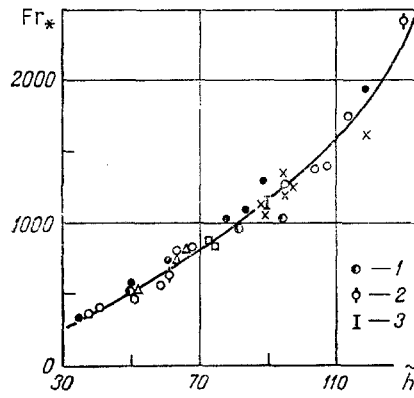

Fig. 4. Generalization of experimental data: 1)  $\bar{h}_0/L = 0.45$ ; 2) 0.54; 3) 1.0. Remaining notation as in Fig. 3.

where  $\bar{h}_0$  is determined by calculation from the equation of constancy of mass of heat-transfer agent in the closed natural circulation circuit or from experimental data.

Solving the system of equations for  $Q_*$ , we obtain

$$Q_* \approx rF_1 \left\{ \frac{gD\rho'_c \left[ \left( \frac{\bar{h}_0}{L} - \frac{\rho''}{\rho'} \right) + \left( 1 - \frac{\bar{h}_0}{L} \right) \frac{\rho'_c}{\rho'} \right]^{1/2}}{\int_0^L \xi \frac{\rho^2(x)}{2} \frac{\rho'_c}{\rho''} \frac{dx}{D} + \frac{D}{L}} \right\} \quad (8)$$

To solve Eq. (8) it is necessary to know the thermal flux distribution over vapor generator channel height at  $Q = Q_*$ , on which the friction loss distribution and heat-exchange agent flow rate depend in boiling under natural circulation conditions with  $\varphi \approx 1$ . We note that use of Eq. (8) is valid when hydraulic losses in the circuit aside from losses in the vapor generator channels can be neglected. Experiments have shown that for the present apparatus this condition is sufficiently satisfied.

To analyze and process the experimental data, Eq. (8) can be reduced to dimensionless form using the Froude number  $Fr_* = \frac{Q_*}{(gD)^{1/2} F_1 r \rho'_c}$  and the quantity  $\tilde{h} = \left( \frac{\bar{h}_0}{L} \frac{\rho'}{\rho'_c} \right)^{1/2}$

$$Fr_* = f(\tilde{h}, \rho(x), \xi, \rho'_c/\rho'') \quad (9)$$

At the moment when the limiting thermal load is attained, the thermal flux distribution over height  $p(x)$  and the structure of the vapor-water mixture flow (i.e., the hydraulic resistance coefficient  $\xi$ ) are defined by the natural circulation parameters ( $\bar{h}_0$ ,  $L$ ,  $D$ ) and the thermophysical characteristics at the given saturation pressure, i.e.,  $p(x)$  and the law of change for  $\xi$  are not independent variables.

The ratio  $\rho'_c/\rho''$  characterizes the change in vapor density over channel height. Its effect on  $Q_*$  increases simultaneously with increase in  $\bar{h}_0$  and  $1/\rho'_c$ , or, what is the same, with increase in  $\tilde{h}$  and  $Fr_*$ . Therefore, this factor will not be considered separately, and we will use the equation  $Fr_* = f(\tilde{h})$  to process the experimental data.

The results of processing for the range  $0.45 \leq \bar{h}_0/L \leq 1$ ,  $29 \cdot 10^3 \leq \rho'/\rho'_c < 1.8 \cdot 10^3$ , specific thermal fluxes  $15 \leq q \leq 60 \text{ kW/m}^2$  for heating vapor superheats of 0 to 30°C, water temperature  $t_{s-2}^{+3}$ , °C, and vapor generation tube submersion levels up to 1 m are presented in Fig. 4. The scattering of the experimental data about the averaged curve does not exceed 20%.

An important advantage of the complexes  $Fr_*$  and  $\tilde{h}$  is that they are completely defined by the heat-transfer agent parameters and the geometric characteristics of the apparatus. Use of experimental data processed with the aid of these complexes is convenient for engineering calculations.

## NOTATION

$q_{cr}$ , critical thermal flux density;  $p(x)$ , function which considers distribution of specific thermal flux  $q$  over height of vapor generator channel;  $x$ , coordinate;  $\rho_c''$ , vapor density above vapor generator channels;  $\rho'$ ,  $\rho''$ , mean density of liquid and vapor over channel heights;  $\rho''$ , local vapor density;  $r$ , specific heat of vapor formation;  $t_s$ , saturation temperature at input to vapor generator channel;  $\bar{h}_0$ , mean height of liquid column in descent tube over water input to vapor generator channel.

## LITERATURE CITED

1. A. P. Simonenko, "Study of heat liberation in cooling agent boiling in vertical tubes," Tr. Nikolaev. Korablestroï. Inst., No. 187, 19-26 (1982).
2. N. V. Tarasova and A. I. Leont'ev, "Hydraulic resistance in flow of a vapor-water mixture in a heated vertical tube," Teplofiz. Vys. Temp., 3, No. 1, 115-119 (1965).
3. O. O. Mil'man, "Limiting thermal loads in boiling in heat exchangers with vertical tubes," All-Union Conference on Thermophysics and Hydrodynamics of Boiling and Condensation Processes. Summaries of Reports [in Russian], Vol. 1, Ryzhsk. Politekh. Inst., Ria (1982), pp. 186-188.
4. S. S. Kutateladze and M. A. Styrikovich, Hydrodynamics of Gas-Liquid Systems [in Russian], Énergiya, Moscow (1976).
5. M. K. Bezrodnyi et al., "Study of limiting heat transfer of inclined two-phase thermosiphons with separation of ascending and descending flows of intermediate heat transfer agent," Promyshl. Energet., No. 5, 44-48 (1982).
6. V. E. Doroshchuk, Heat Exchange Crises in Water Boiling in Tubes [in Russian], Énergoatomizdat, Moscow (1983).

## CALCULATION OF DIFFUSION SEPARATION PROCESSES IN GAS MIXTURES

E. P. Potanin

UDC 533.735

The selective action of various types of force fields on isotopic gas mixtures is considered using the multicomponent hydrodynamic approximation. It is shown that it is possible to indirectly estimate the intensity of mutual diffusion and the separation effect in all cases of practical importance.

Calculation of the degree of enrichment of an isotopic gas mixture achievable in an individual separation device involves analysis of mutual diffusion of the components under the action of various types of force field [1-8]. Separation may be produced by the selective action on the mixture of not only purely external forces, produced by, for example, "gravity-like" (centrifugal [1, 4], gravitational) or electromagnetic fields [2], but also forces of an internal nature, among which, in particular, are viscous forces [3], as well as diffusion friction forces [4-6]. Multiple separation processes are found in plasma devices (the plasma centrifuge [4, 9, 10], traveling magnetic wave system [5, 11], dc discharge [12, 13]), in which several separation mechanisms may operate simultaneously. Among such mechanisms, in particular, are thermodiffusion and the centrifugal effect, mass diffusion and mechanisms related to the differing degree of ionization of the components. A recent analysis of enrichment processes in plasma systems permits formulation of a simple general method for calculating diffusion separation phenomena in the presence of a pressure gradient within the gas.

To determine the mutual diffusion rate of the components of a binary gas mixture we will use the multicomponent hydrodynamic approximation [4]. The equations of equilibrium of the volume forces acting on the mixture components can be written for the general case in the form

---

Translated from *Inzhenerno-Fizicheskii Zhurnal*, Vol. 48, No. 4, pp. 628-632, April, 1985. Original article submitted March 21, 1984.